

## TU-302 CONTROL BOARD, ELECTRIC HEAT TRAINER

*This trainer is perfect for students to learn the basics of electric heat control systems.*

### Specifications

Electrical Requirements: 120VAC, single phase, 60 Hz

Overall Size: 35"L x 13"W x 30"H

Weight: 70 lbs.

### Features

- Complete set of operating controls of an electric furnace
- Wired 3 element furnace circuit
- Simulated heater elements operation shown by signal lamps
- Sequences
- Klixon limit switch
- Fusible link safety device
- Thermostat
- Transformer steps voltage from 120 VAC to 240 VAC
- Fan delay control
- Board designed for use on a bench or table
- Includes Instructor Guide

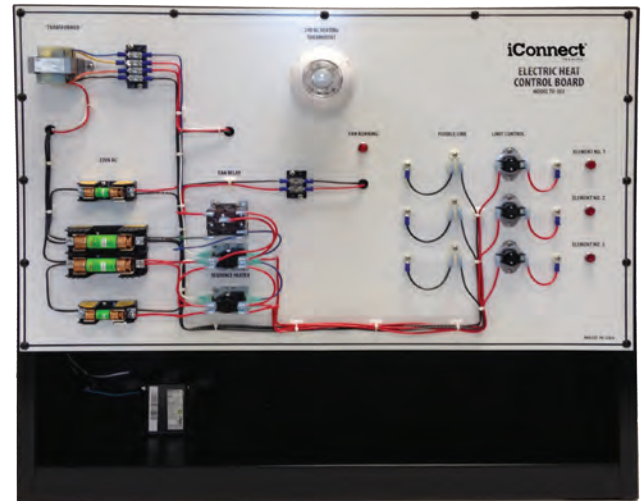

**Shipping Weight: 110 lbs.**

**Shipping Dimensions: 37" L x 48" W x 40" H**

## TU-502 GAS FIRED HEATING CONTROL BOARD

*The control board contains a complete set of electrical controls for a furnace, with air conditioning, to demonstrate basic principles and provide electrical service experience.*

### Specifications

Electrical Requirements: 120VAC, single phase, 60 Hz

Overall Size: 35"L x 13"W x 30"H

### Features

- All components are panel mounted and the wires are brought to terminals on the front panel
- Equipped for both thermocouple and thermopile systems
- Signal lamps show simulated operation of burner valves, circulating fan air, and air conditioning compressor

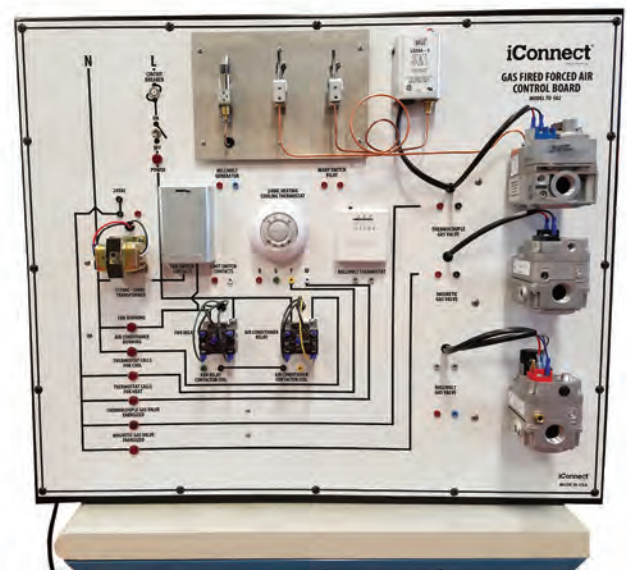

**Shipping Weight: 130 lbs.**

**Shipping Dimensions: 37" L x 48" W x 40" H**

**iConnect**<sup>®</sup>  
TRAINING